



## AZEK Bevel Siding Install Guide

<b>CRITICAL WARNINGS, CONSIDERATIONS, &amp; CLEANING</b> .....	<b>2</b>
<b>PAINT REQUIREMENTS</b> .....	<b>3</b>
<b>STORAGE, TOOLS, &amp; CUTTING</b> .....	<b>4</b>
<b>GENERAL REQUIREMENTS, TRIM, &amp; FASTENERS</b> .....	<b>5</b>
<b>BEVEL INSTALLATION</b> .....	<b>6-7</b>
<b>NOTES</b> .....	<b>8</b>

AZEK Bevel Siding must be installed using the same good building principles used to install traditional siding products and in accordance with the local building codes and the installation guidelines included below. AZEK Building Products accepts no liability or responsibility for the improper installation of this product.

Applications outlined in this install guide are the only applications that are currently recommended for this product. Do not install this product in applications not outlined in this install guide.

AZEK Bevel Siding may not be suitable for every application, and it is the sole responsibility of the installer to be sure AZEK products are fit for the intended use. Since all installations are unique, it is also the installer's responsibility to determine specific requirements for each application.

AZEK Building Products recommends that all applications be reviewed by a licensed architect, engineer or local building official prior to installation. If you have any questions or need further assistance, please call AZEK Customer Service at 1-800-910-3545 or visit our website at [AZEKexteriors.com](http://AZEKexteriors.com)

### IMPORTANT

The building structure and outside wall must be built to code, be weather-tight and waterproof, and have proper horizontal flashing and kick-out flashing prior to installing AZEK Bevel Siding. AZEK Bevel Siding will not solely protect against moisture penetration to the building or structure. Refer to your local building codes for wall construction, house wrap waterproofing, flashing and other wall preparations prior to installing AZEK Bevel Siding.

### ENVIRONMENTAL CONSIDERATIONS

AZEK Bevel Siding will experience expansion and contraction with changes in temperature, unlike wood and other products whose size will fluctuate with moisture changes. Fastening the boards according to the Installation Guidelines will help to minimize the effects of expansion and contraction.

- Expansion/contraction is most significant where extreme temperature changes may exist
- Prior to and during installation, keep product at a mild temperature. In warm installation, keep product as cool as possible by keeping them covered and out of direct sunlight
- EXTREME COLD: use extra care when handling and installing the product. Do not install product when temperatures are below 25 degrees Fahrenheit

### EXTREME HEAT WARNING

Be aware of excessive heat on the surface of AZEK Bevel Siding from external sources, such as (but not limited to) fire or reflection of sunlight from energy-efficient window products. Low-emissivity (Low-E) glass can potentially harm AZEK products. Low-E glass is designed to prevent passive heat gain within a structure and can cause unusual heat build-up on exterior surfaces from sunlight reflection. This extreme elevation of surface temperatures, which can exceed that of normal exposure, can possibly cause AZEK products to melt, sag, warp, discolor, increase expansion/contraction, and accelerate weathering.

### PAINT WARNING

**AZEK Bevel Siding can be painted any color, however the proper type of paint MUST be used to limit heat build. Using the incorrect paint may cause severe damage to the product and void the warranty.**

See page 4 for more details

### STORAGE & HANDLING

Store AZEK Bevel Siding laying down on a flat and level surface that fully supports the product.

DO NOT store AZEK Bevel Siding in areas of excessive heat, such as on asphalt, directly on a asphalt roof, in direct sunlight, or under dark tarps or coverings.

Always leave the manufacturer's protective wrap on the product until installation. If removed, replace the protective wrap, or use a different non-translucent cover, to keep the product free from dust and construction debris. DO NOT cover with a dark covering or tarp.

If banding is used, place protective corners between the product and banding to prevent indents.

Always remove job site dust, clay, dirt, mud, debris and other job site contaminants and products from AZEK Bevel Siding right away.

**IMPORTANT:** Do not allow airborne dust from concrete, landscape blocks, or any masonry product to accumulate on AZEK Bevel Siding as they may damage the surface.

### TOOLS REQUIRED

AZEK Bevel Siding can be installed with a minimum number of readily available tools. Many other tools are available that can be used for installation. All tools should be used in accordance with the manufacturer's instructions.

Some of the basic tools required for installation:

Safety Glasses	Pencil or Marker
Ear Protection	Hammer
Chalk Line	Coil Siding Nailer
Tape Measure	Miter Saw or Circular Saw
Square	Jig Saw
Level	Caulking Gun

### CUTTING RECOMMENDATION

For best cutting results, use a miter saw or a circular saw with a fine-toothed, carbide tipped finish trim blade. To cut around obstructions, use a jigsaw with a fine-toothed blade.

When working with AZEK products, be sure to wear proper clothing and safety equipment. Safety glasses should be used during the entire installation process.

**PAINTING REQUIREMENTS**

If your desired color does not meet a Light Reflective Value (LRV) of 55 or higher you must either choose a pre-set color from a paint designed for vinyl or have the color matched using a specialty paint with solar reflective pigments. Paints formulated for vinyl and paints with solar reflective pigments are designed to limit heat build and ensure the long term performance of your PaintPro® products. Always make sure your paint is suitable for exterior application.

- AZEK Bevel siding must be painted within 180 days of installation
- To maximize paint performance, the product should be kept covered and away from sunlight before installation at a job site
- The surface must be clean, dry, and void of any foreign material such as dirt, oil, grease or other contaminants that may come from normal handling, storage and/or installation prior to painting. Refer to the storage and handling guidelines on page 2 for more details
- Paints used on AZEK Bevel siding will dry to the touch quickly. As with any product, ensure the panels are properly cured before handling and stacking
- **DISCLAIMER:** The Lifetime Limited Warranty on AZEK Bevel Siding does not cover the performance of painted finishes or coating applied to the product by the original purchaser or any third party

**Paint Type Requirements**

COLOR RANGE	KEY COLOR SELECTION CRITERIA	PAINT TYPE
Lighter paint colors only	Must have a light reflective value (LRV) above 55	Exterior 100% acrylic latex
Light, medium, and some darker colors	Only use colors that are from a paint manufacturer's approved color list for vinyl siding. No custom colors.	Exterior 100% acrylic latex made for vinyl siding
Dark colors & custom colors	Available via Special Order only. Visit our custom colors and special-order paint page. <b>Never custom color match in local paint stores.</b>	Exterior 100% acrylic latex with solar reflective pigments

**REMEMBER:** Always make sure your paint is 100% water-based (acrylic) and suitable for exterior application.



**WARNING**

Do not adjust or customize colors at local paint stores, home centers, big box stores, or other paint providers. These have not been tested for use on AZEK products and may lead to defects. For info on custom colors visit: [azekexteriors.com/painting/custom-colors](http://azekexteriors.com/painting/custom-colors)



CUSTOM COLOR & SPECIAL-ORDER



PAINT GUIDELINES

**GENERAL REQUIREMENTS**

The building structure and outside wall must be built to code, be weather-tight and waterproof, and have proper horizontal flashing and kick-out flashing prior to installing AZEK Bevel Siding. AZEK Bevel Siding will not solely protect against moisture penetration to the building or structure. Refer to your local building codes for wall construction, house wrap waterproofing, flashing and other wall preparations prior to installing AZEK Bevel Siding.

**SHEATHING / SUBSTRATE**

- ENSURE wall is flat, even and in plane prior to installation. AZEK Bevel Siding will contour to undulation in the substructure
- Minimum 7/16" OSB installed over 16" on-center studs

**WEATHER-RESISTANT BARRIER**

- Install WRB in accordance with the local building code
- For best results, use a drainable WRB

**FLASHING**

- Install kick-out flashing in accordance with the local building code
- Install all other horizontal flashings in accordance with the local building code

**FASTENERS**

- Use 0.092" diameter with a minimum 2" length hot-dipped galvanized or stainless-steel ring shank nail
- Starter strips can be installed with 15- or 16-gauge exterior grade finish nails
- Fasteners should be snug or flush; do not over driven

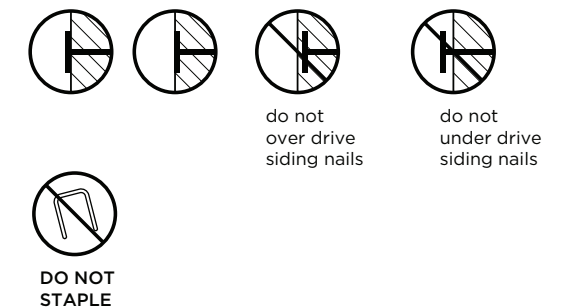
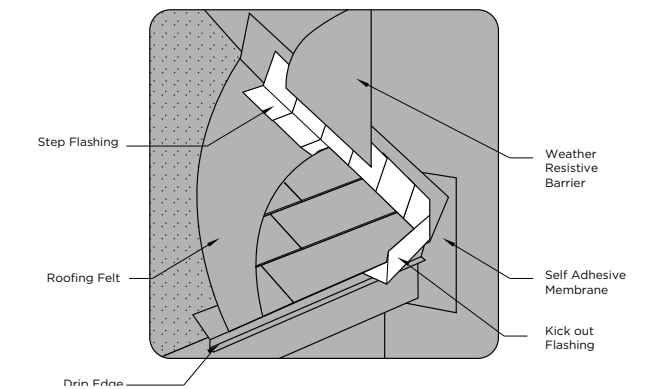
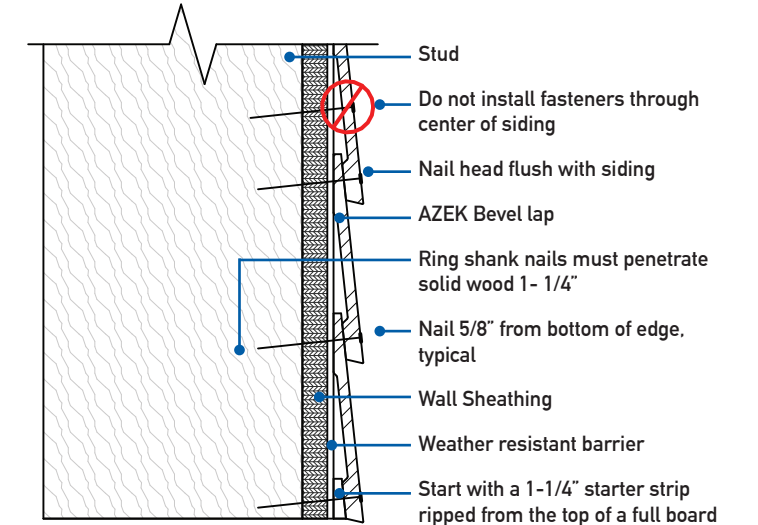

**INSTALLATION METHOD**

- A. EXPOSURE**
  - AZEK Bevel Siding is a 5.25" wide board designed for a 4" exposure
- B. SETBACKS**
  - 32" setbacks are recommended to offset seams
- C. STARTER STRIPS**
  - Rip 1-1/4" starter strips from the top of AZEK Bevel Siding boards
  - Fasten every 8" along the bottom of the install area using 15- or 16-gauge exterior grade finish nails
- D. SIDING FASTENER LOCATIONS**
  - Fasten with the recommended fastener with a maximum spacing of 16" between fasteners
  - For high wind zone areas, and for best results, fasten into studs
  - Fasteners must be 5/8" up from the bottom of the board. High or low fasteners may cause cracks
  - DO NOT fasten within 2" of from ends of the board

- E. GAPPING**
  - Install all butt joints with moderate contact. DO NOT force boards into place
  - Leave a 1/4" gap above all horizontal flashings. DO NOT caulk gap between siding and horizontal trims
  - For face-caulking, leave an 1/8" gap between the siding and trims, then caulk
  - For back-caulking, siding can be installed tight to the trims
- F. JOINT FLASHING**
  - Use a joint flashing wherever 2 boards butt together

**IMPORTANT**

**ENSURE SOLID BACKING**

- If the exposure of the last course of siding is 3-1/2" or less it will require the space between the previous course of siding and the frieze board / soffit, bottom window trim, or other break to be packed out to maintain the proper angles
- A 1-1/4" starter strip ripped from the top of a siding board is recommended

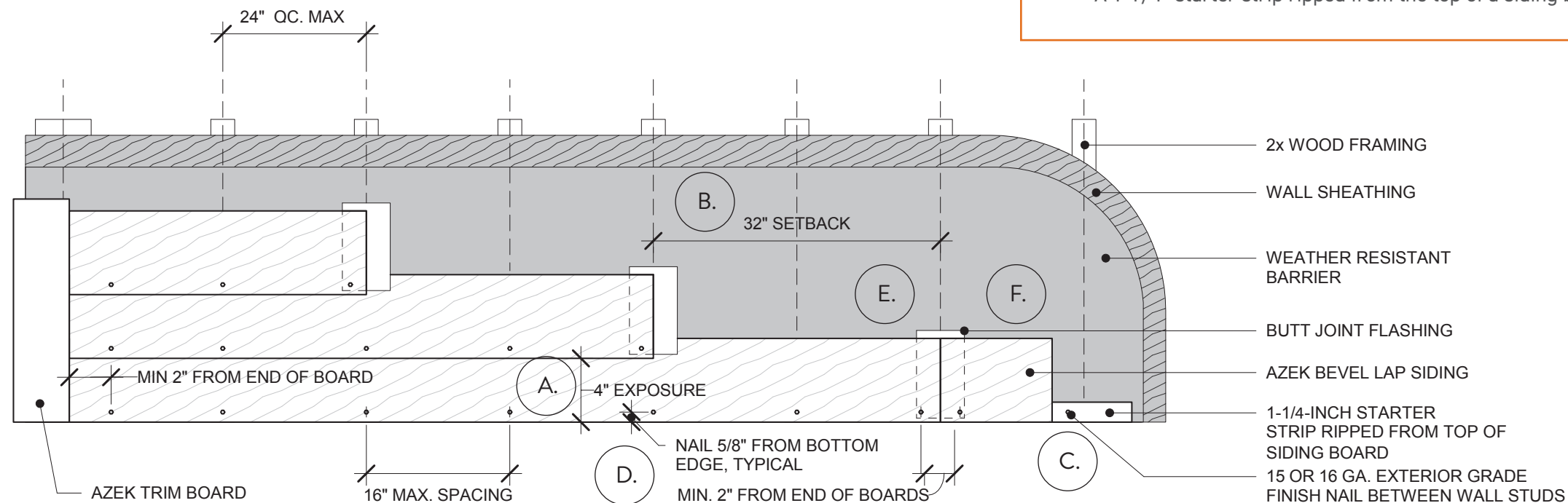

**CARE AND CLEANING**

- Use warm water and a brush, or power wash with a fan tip, to clean off any loose dirt or debris. Make sure to test the pressure of the power washer prior to using it on AZEK Bevel Siding products to ensure it will not damage the surface.
- DO NOT USE any chemical cleaners on the product prior to painting as they may affect the paint adhesion and paint performance over time.
- For PAINTED siding, please refer to the paint manufacturer's recommendations for cleaning.
- IMPORTANT: DO NOT USE SOLVENT BASED CLEANERS AS THEY CAN DAMAGE THE FINISH OF AZEK BEVEL SIDING PRODUCTS.
- WARNING: KEEP CHILDREN AND PETS AWAY FROM CLEANING PRODUCTS AND THE CLEANED MATERIAL UNTIL IT IS COMPLETELY DRY.
- For any other questions on AZEK Bevel Siding, call us at 1-800-910-3545.

**AZEK Exteriors**  
**1330 West Fulton St. Suite #350**  
**Chicago, Illinois 60607**

**AZEKexteriors.com • 1-800-910-3545**